

S60F

WOOD STOVES



mm 680x660xh1450

CE EN -13240 certification

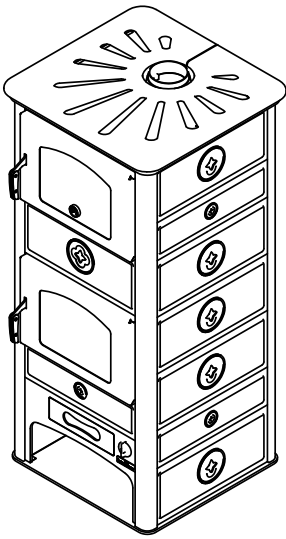

S60F

Ceramic tiles white, bordeaux or serpentine stone

## STANDARD EQUIPMENT

- above flue  $\varnothing$  150 mm
- safety heat exhaust outfitted for connection to a close circuit
- oven of mm 350x520xh240
- oven features: 1 grid + 1 baking pan
- primary air thermostatic regulation
- external flue air  $\varnothing$  80 mm

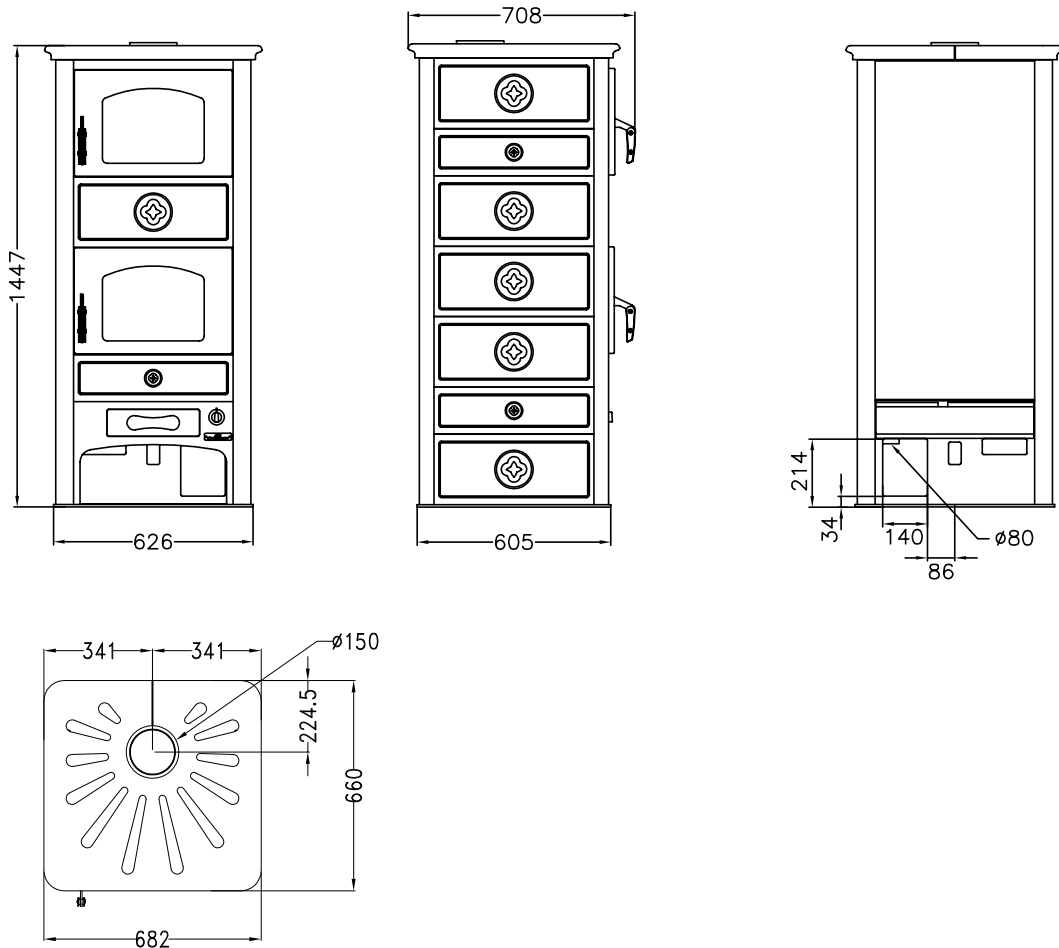

## DATA SHEET

Energy Efficiency Class: A+	Efficiency: 85.1 %
Nominal heat output: 13.5 kW	Mean content of CO to 13% O <sup>2</sup> : 0.05 %
Max heat output: 16.0 kW	Average DUST content to 13% O <sub>2</sub> : 20.0 mg/Nm <sup>3</sup>
Firebox capacity (LxPxH): 33x36x45 cm	Fill opening (LxH): 35x25 cm
Mean flue gas temperature: 230 °C	Flue gas mass flow: 11.0 g/s
Flue depression: mbar 0.12	Net weight/packaging included: kg 270/290